

Supplier Quality Assurance Requirements

Approvals	
<i>Note: Approvals are requested and collected Electronically, consult evidence on Share ITT Intranet System</i>	
Steve Williams	Manager, QA Engineering - Irvine
Carlos Benitez	Manager, BQMS
Ana Ruiz	Supervisor, Supply Quality
Juan P. Curiel	Manager, Purchasing
Manuel Camacho	Manager, Quality Assurance - Nogales
Carolyn Go	Manager, Cost Accounting

1.0 PROCESS OWNER
 Supplier Quality Supervisor

2.0 PURPOSE

To assure customer satisfaction, aerospace industry organizations must produce, and continually improve, safe, reliable products that meet or exceed customer and regulatory agency requirements. The globalization of the aerospace industry, and the resulting diversity of regional/national requirements and expectations, has complicated this objective. End-product organizations face the challenge of assuring the quality of, and integrating, product purchased from suppliers throughout the world and at all levels within the supply chain. Aerospace suppliers and processors face the challenge of delivering product to multiple customers having varying quality expectations and requirements.

This document standardizes, to the greatest extent possible, individual contract requirements for the aerospace industry. The establishment of common requirements, for use at all levels of the supply-chain, by organizations around the world, should result in improved quality and safety, and decreased costs, due to the elimination or reduction of organization-unique requirements and the resultant variation inherent in these multiple expectations.

3.0 SCOPE

This Supplier Quality Assurance Requirements document applies to ITT Cannon LLC (ITT); it establishes quality requirements for the suppliers to ITT that provide inventory products, special processes, calibration services, acceptance test equipment.

The Supplier Quality Assurance Requirements are invoked as a Purchase Order (“PO”) requirement. In the event of conflicting requirements, the PO takes precedence.

4.0 REFERENCE DOCUMENTS

4.1 ITT Documents

- 4.1.1 QAP-08 Supplier Control Procedure
- 4.1.2 QAP-04 Purchase Order/Contract Review Procedure
- 4.1.3 QAP-011 Supplier Quality Requirements
- 4.1.4 QAP-091 Records
- 4.1.5 MAP-05 Supplier Information Request (SIR) Procedure

4.2 External Documents

4.2.1 **SAE Publications**, www.sae.org

- AS478 Identification Marking Methods
- AS5553 Fraudulent/Counterfeit Electronic Parts; Avoidance, Detection, Mitigation, and Disposition
- AS6174 (current release) - Counterfeit Material; Assuring Acquisition of Authentic and Conforming Material
- AS9100 Quality Management Systems – Requirements for Aviation, Space and Defense Organizations
- AS9120 Quality Management Systems – Requirements for Aviation, Space and Defense Distributors
- AS9102 Aerospace First Article Inspection Requirement
- AS9103 Inspection and Test Quality Systems Requirements for Aviation, Space, and Defense Organizations
- AS9110 Quality Maintenance Systems - Aerospace - Requirements for Maintenance Organizations
- AS9131 Quality Systems Non-Conformance Documentation

4.2.2 **Commercial Publications**, www.idofea.org

- DEA-STD-1010 Acceptability of Electronic Components Distributed in the Open Market

4.2.3 **ISO Publications**, www.iso.org

- ISO 17025 - General requirements for the competence of testing and calibration laboratories

- ISO 10012-1 Quality assurance requirements for measuring equipment

4.2.4 **ASTM Publications, www.astm.org**

- ASTM D3951 Standard Practice for Commercial Packaging
- ASTM E1417 Standard Practice for Liquid Penetrant Testing

4.2.5 **Other Documents:**

- AC7004 Aerospace Quality System – NADCAP
- AIM BC1 Uniform Symbology Specification - Code 39
- ANSI/ ESD S20.20 - For the Development of an Electrostatic Discharge Control Program for – Protection of Electrical and Electronic Parts, Assemblies and Equipment
- ANSI/ESD S541 For the Protection of Electrostatic Discharge Susceptible Items Packaging Materials
- ATA Spec 300 Specification for Packaging of Airline Supplies (A4A)
- CRF Title 49 Hazmat Transportation Regulations For Domestic Shipping and Transporting of Hazardous Materials
- HM181 Hazardous Materials Safety Regulation
- ISPM 15 International Standards For Phytosanitary Measures No. 15
- JESD625 equipments for Handling Electrostatic-Discharge-Sensitive (ESDS) Devices
- IPC/JEDEC JSTD-033 Handling, Packing, Shipping and Use of Moisture/Reflow Sensitive Surface Mount Devices
- MIL-DTL-117 Bags, Heat-Sealable
- MIL-PRF-22191 Barrier Materials, Transparent, Flexible, Heat-Sealable
- MIL-STD-130 Identification Marking of U.S. Military Property
- MIL-STD-2073-1 Standard Practice for Military Packaging
- NAS 412 Foreign Object Damage / Foreign Object Debris (FOD) Prevention
- Z540-1/Z540.3 General Requirements for Calibration Laboratories and Measuring and Test Equipment, General Requirements (NCSL)

4.3 Forms

- QAF-02 – ITT Supplier Contract Quality Agreement
- MAF-02 – Supplier Information Request Form

5.0 GUIDING PRINCIPLES

The following convention is used in all BQMS documentation:

- The words shall, will and must indicate mandatory requirements
- The word should indicates requirements with some flexibility allowed in compliance methodology. An Organization is permitted to show that its approach meets the

intent of the requirement and this standard Words may, typical, example or e.g. show suggestions given for guidance only

6.0 INPUTS / OUTPUTS

Inputs:

- Purchase Order
- Customer flow down requirements
- Regulatory requirements
- ITT requirements
- General and special product assurance requirements

Outputs:

- ITT Source inspection at supplier facilities
- Government inspection at supplier facilities
- Documented evidence of compliance to requirements
- Corrective action / improvement plans

7.0 DEFINITIONS

- 7.1 **CCT** – Connect & Control Technologies division
- 7.2 **HAZ MAT** - shortened form of "hazardous materials," which the U.S. Department of Transportation describes as materials that could adversely affect people and the environment. Hazmat certification is required for workers who handle, remove or ship hazardous materials.
- 7.3 **IATA** - Acronym for The International Air Transport Association is a trade association of the world's airlines.
- 7.4 **IMDG**- International Maritime Dangerous Goods Code.
- 7.5 **ICAO**- International Civil Aviation.
- 7.6 **HM 181**- Hazardous Materials Training
- 7.7 **SAE** - Society of Automotive Engineers
- 7.8 **NCSL** - National Conference of State Legislatures.
- 7.9 **FOD** - Foreign Object Debris
- 7.10 **ANSI** - American National Standards Institute
- 7.11 **ESD** – Electro-Static discharge
- 7.12 **DoD** - U.S. Department of Defense
- 7.13 **EPA** - Environmental Protection Agency
- 7.14 **RoHS** - Restriction of Hazardous Substances
- 7.15 **REACH** - Registration, Evaluation, Authorization and Restriction of Chemicals
- 7.16 **ODC** – Ozone Depletion Chemicals
- 7.17 **DFARS** - Defense Federal Acquisition Regulations Supplement
- 7.18 **FAIR** – First Article Inspection
- 7.19 **GSI** – Government Source Inspection
- 7.20 **GMIPs** - Government Mandatory Inspection Points
- 7.21 **NADCAP** - National Aerospace and Defense Contractors Accreditation Program
- 7.22 **EEE** -Electrical, Electronic and Electromechanical

- 7.23 **Special Process** – any process where it may not be practical or feasible to verify the results of the process without destructive testing of parts (i.e. heat treat, plating).
- 7.24 **Tier-1 Supplier** – The Supplier accepting the purchase order directly from ITT.
- 7.25 **Sub-Tier Supplier** – A supplier to the Tier-1 for materials or processes in connection with the product sold to ITT.

8.0 RESPONSIBILITIES

- 8.1 ITT Cannon LLC keeps Supplier Quality Assurance Requirements aligned on customer flowed down requirements and regulatory requirements.
- 8.2 The present document may be communicated and provided to the supplier base through Procurement and/or Supplier Quality representatives.
- 8.3 Supplier to acknowledge and review this document for compliance confirmation proposes, and when required, ITT will retrieve formal response to applicable requirements.
- 8.4 The Tier-1 supplier shall ensure that all applicable requirements that are invoked or applied to the customer's purchasing document, including this clause, shall be flowed down to the Tier1's sub-tier suppliers.

Latest Revision of QAP-011 is available at the following web address:

<https://www.ittcannon.com/terms-conditions/>

9.0 ENVIRONMENTAL, SAFETY AND HEALTH

Not applicable

10.0 PROCEDURE

- 10.1 ITT Cannon LLC to flow down customer requirements through in this document, per QAP-04 Purchase Order/Contract Review.
- 10.2 Supplier to review Supplier Quality Requirements and assure compliance. All exceptions shall be expressly approved by ITT Cannon LLC.
- 10.3 **Quality Clauses:**

Q-1 Configuration control

Supplier shall be responsible for controlling/tracking changes to parts and components manufactured to ensure that the product meets specified functional and physical requirements of the contract. This includes any part or component manufactured to customers' or vendors' drawings, specifications, or special process procedures.

The Supplier and the ITT Cannon LLC shall document agreements as to the extent of customer involvement in configuration management to apply to this contract/purchase order.

At a minimum, with each shipment, organization shall submit “configuration documents”, which define the requirements, designs, build/production and verification for a configuration-controlled item.

This record shall contain, signature and dated of an official of the organization’s Quality department, and in addition to the aforementioned required information, shall include the following minimum requirements:

- Organization’s Contract/Purchase Order number
- Line item number (if applicable)
- Part number (of deliverable item and all traceable/repairable sub-tiered parts)
- Serial number (Traceability as required per contract/purchase order)
- Lot number (Traceability as required per contract/purchase order)
- Drawing number (for Drawings related to deliverable item and all traceable/repairable sub-tiered parts)
- Revision level (baseline configuration of drawing to which hardware was built)
- Revision level (baseline configuration of Standard and or ITT Finish Specification to which hardware was processed) applicable for special processes
- Engineering order(s) (or equivalent drawing changes as applicable)
- Customer approved deviations and waivers (as applicable)

Q-2 Restrictions for use of Mercury and or Mercury Containing Components (Mercury Contamination Certification)

Products shall contain no metallic mercury and must be free from contamination by mercury. The Supplier shall not use mercury, mercury components or mercury bearing instruments or equipment that cause the contamination during the manufacture, service, assembly, or test of materials.

- a) Mercury-bearing instruments and/or equipment, which might cause contamination, shall not be used in the manufacture, fabrication, and assembly or testing of any material furnished under this purchase order.
- b) In the event of any accident, involving mercury contamination of the material furnished on this purchase order or suspicion of such contamination, ITT Cannon LLC shall be notified immediately.
- c) Supplier’s sub-contractors must be notified of and must comply with the requirements of this notice
 - a. The Supplier shall send a signed statement with the shipment that tells that the items are free of mercury and free from mercury contamination, the statement must include:
 - i. The Contract Number
 - ii. The National Stock Number (NSN), as applicable
 - iii. The Manufacturer’s Code (CAGE) and Part Number or the Specification or Drawing Number
 - iv. The date of shipment and the quantity shipped

- v. This paragraph must be noted as below, or words that convey the same meaning:

“The undersigned certifies that the items shipped conform to the requirements of the Purchase Order. The items are free from mercury contamination. Mercury-bearing instruments and equipment which can cause mercury contamination were not used in the manufacture, service, assembly, or testing of the items supplied.”

The statement must contain the signature of a corporate or company officer.

Inclusion of Mercury

If the inclusion of metallic mercury is required as a functional part of the items supplied, the Supplier shall obtain written approval from ITT Cannon LLC prior to delivery and shall supply a “Warning Plate” to show that metallic mercury is a functional part of the item. The label must identify the name and the location of the part or component.

Q-3 Customer Source Inspection (CSI):

Customer source inspection is required prior to shipment of articles from the organization’s facility. Upon receipt of this order and prior to commencing work, promptly notify the customer’s Procurement Quality Assurance Representative (PQAR) assigned to the organization’s facility so the appropriate inspection plan can be coordinated.

In the event that a PQAR does not normally service the organization’s facility, immediately notify the customer procurement representative to obtain a point of contact for the appropriate PQAR assignment.

Source inspection shall be conducted by the customer at the organization’s facility or where designated in the order. The organization shall notify PQAR office a minimum of 5 working days in advance of the time the articles or materials are ready for inspection or test.

Q-4 Supplier’s Quality Control System

The core quality requirement is for all features to comply to specifications 100% for all parts produced and shipped. If the process is not capable of meeting 100% yield it is ITT Cannon LLC’ expectation that all suppliers pursue measurable continuous quality and delivery improvements.

ITT Cannon LLC defines the minimum performance expectation measured in conventional ways like Parts per Million (PPM) for quality and Percent on Time Delivery on a supplier level as well as on a part number level.

When Supplier does not meet these minimum performance levels, ITT Cannon LLC reserves the right to require Supplier to engage in an aggressive improvement project – lead by Supplier’s leadership as well as ITT Cannon LLC Stakeholders. Focus of these projects will be Supplier Business Operating Systems’ improvement that will result in the sustainable achievement of ITT Cannon LLC’ minimum performance expectation.

Supplier and supplier sub-tiers providing product are responsible for maintaining Quality Systems that are compliant to applicable ITT Cannon LLC Quality System Requirements. Supplier should be third party registered, or may be subject to periodic compliance audits by ITT Cannon LLC at the discretion of Supplier Quality. Supplier assumes the cost of systems audits. ITT Cannon LLC' preferred Quality Systems levels are as follows:

- **Manufacturing with Design Authority:** AS/EN/JISQ 9100; design must be included in scope of Registration and suppliers may not exclude design portions of the Standard.
- **Manufacturing without Design Authority / Special Processes:** AS/EN/JISQ 9100
- **Repair and Overhaul:** National Aviation Authority (NAA) Certification (local and/or international Regulatory agency) and/or AS9100 or AS9110
- **Special Processors (non-manufacturing):** AS9003 or satisfactory audit to NADCAP (AC7004)
- **Materials Laboratories and NDT Laboratories:** ISO 17025, or AS9003, or satisfactory audit to NADCAP (AC7004)
- **Distribution and Brokers:** AS/EN/JISQ 9120
- **Calibration Laboratories:** ISO 17025

Q-5 Gauge and Measuring Device Control

Supplier shall have a documented calibration system that meets the requirements of ISO 10012-1, 'Quality assurance requirements for measuring equipment', or the American National Standard Institute (ANSI)/National Conference of Standards Laboratories (NCSL) Z540-1/Z540.3, 'General Requirements for Calibration Laboratories and Measuring and Test Equipment' standards".

Suppliers to ITT must perform calibration per the measuring device manufacturer's recommendation, unless otherwise defined by ITT on a purchase order.

Q-6 Commercial Shipping Documents/Packing List

Organization shall furnish Commercial Shipping Documents/Packing List, capable of being photographically reproducible through two additional reproductions, showing the following (as applicable):

- P.O. Number
- Part Number(s)
- Description
- Quantity ordered
- Quantity shipped
- Lot/Date Code/serialization (as applicable)
- Any handling constraints or cautions such as, but not limited to:
 - Optics; open only in clean room environments.
 - ESD sensitive items open only at approved ESD workstation.
 - Moisture sensitive components, open/store only in humidity controlled area.
 - Shock sensitive components (shock monitoring should be specified if required)

Q-7 Certificate of Compliance - Products:

Organization shall provide a certification with each shipment to attest that the parts, assemblies, subassemblies, or detail parts conform to the order requirements. A hardcopy of the certificate shall be included with the shipment, and an electronic copy shall also be e-mailed to supplier.compliance@itt.com. The applicable material test results, process certifications and inspection records shall be available to ITT upon request.

The certificate serves as evidence that inspections necessary to determine the acceptability of all articles under this order were completed. When applicable, the true manufacturers, lot, heat, batch, date code, and/or serial number must appear on the certification. All articles submitted in a certificate are subject to final acceptance by the customer.

Refer to section Q-21 for details regarding Certificate of Conformance (C of C) requirements.

Q-8 Certificate of Compliance for Raw Materials:

Organization will include with each shipment the raw material manufacturer's test report (e.g., mill test report) that states that the lot of material furnished has been tested, inspected, and found in compliance with the applicable material specifications.

The test report will list the specifications, including revision numbers or letters, to which the material has been tested and/or inspected and the identification of the material lot to which it applies. When the material specification requires quantitative limits for chemical, mechanical, or physical properties, the test report will contain the actual test and/or inspection values obtained.

For aluminum mill products (except castings), certifications for chemistry may indicate compliance within the allowed range. Certifications for physical properties will show actual values.

When organization supplies converted material produced by a raw material manufacturer, the organization shall submit all pre and post conversion chemical/physical tests reports.

Q-9 Certificate of Compliance for Calibration Service providers:

Suppliers to ITT must perform calibration per the measuring device manufacturer's recommendation, unless otherwise defined by ITT on a purchase order.

The organization shall submit for each item calibrated, one reproducible record of actual calibration results, including applicable graphic and tabular data. Records shall be traceable to the individual item tested, by part number, serial number and customer's order number for the item shipped. The organization's calibration certificate shall include a unique calibration tracking number, tolerance range as per manufacturer's recommendations, uncertainty and when applicable, environmental conditions for each parameter calibrated. The certificate shall also state the operating error per specification, the degree of correction of out of tolerance condition and remaining uncorrected out of tolerance condition, if applicable.

Q-10 Component Traceability (lot control and material traceability)

The Supplier of any component assembly shall be able to, upon request, provide a list of all material utilized in the creation of said assembly. Material requiring this work order to lot/date code level traceability includes electrical components, the active and passive parts and items in the schematic. It does not include non-critical parts such as hardware and other mechanical parts.

The list shall contain as applicable:

- Work order number
- Serial number range in the work order

For each electrical component used in the work order:

- The component name
- ITT Cannon LLC part number
- Reference designators where this ITT Cannon LLC part number is used
- Quantity used per assembly
- Component OEM manufacturers used in the work order
- Manufacturer part numbers used in the work order
- Lot numbers and / or manufacturing dates used in the work order
- Also required to be provided upon request, is the component distributor and procurement date of each component listed

The system must account for any/all components that require replacement past initial installation.

The traceability shall be maintained throughout the manufacturing process from work order launch to shipping to ITT Cannon LLC In addition to the component traceability the supplier shall, upon request, provide all necessary processing history for the assembly in question. Including process name, date and time, location and operator ID of the personnel performing the function.

Q-11 Control of Items with Limited Shelf-Life* (Age control and material traceability)

This defines remaining life requirements and the communication of date control information on items that require shelf life control per their product specification. Typical commodities that require shelf life controls are:

- Uncured compounds (for example: paint, adhesives, curing agents, primers, film adhesive, varnishes, elastomeric molding compounds, pressure sensitive adhesives, sealants, inks etc.)

NOTE: Items such as tapes and labels which have pressure sensitive adhesive (PSA) back are categorized under uncured compounds.

- Cured Elastomers (i.e. O-rings, gaskets, plate seals, molded shapes etc.)

- Electronic Components

Q11.1 System for Shelf Life and Storage Life Control

Supplier shall maintain a documented system for using, storing and controlling items with limited shelf or storage life. The system shall include a method of identifying and controlling such items to ensure expired items were not used in products shipped to ITT Cannon LLC and that items shipped met remaining life requirements.*

Shelf life shall apply per manufacturer expiry date or “use-by” date but not supersede applicable specifications. The buyer must approve all exceptions prior to shipment.

Q11.2. Requirement *

Item	Percentage of Shelf Life required to be remaining upon receipt by ITT (unless otherwise specified by ITT, Military, or Industry product specification or PO line item flow down)	Data Requirements	Identification Requirements
Uncured Compounds	75% Minimum but not less than 6 months	See Q11	Traceability of expiration date to unit container marking. (i.e. via lot, batch, PO, or direct marking of expiration date).
Cured Elastomers-Uninstalled	75% minimum of life	See Q11	Cure date and/or Storage Life expiration date on the part or container as defined by applicable specification or flowed by customer
Cured Elastomers-Installed	N/A	Supplier to retain evidence of Storage Life compliance	Assembly Date marking if required by assembly design requirements
Lubricants/Grease (Containers)*	75% minimum of life as defined by material manufacturer but not less than 18 months	See Q11	Traceability of expiration date to unit container marking. (i.e. via lot, batch, PO, or direct marking of expiration date).
Installed Greases	N/A	Supplier to retain evidence of Storage Life compliance	Assembly Date marking if required by assembly design requirements

Q11.3 Cure Date Identification for Storage Life Controlled Elastomers

Elastomeric parts shall be identified by marking the cure date (quarter and year) on the part or container.

This document and the information contained herein are the property of ITT CCT; copies are issued in strict confidence and shall not be reproduced or copied, or used as the basis of manufacture or sale of apparatus without permission.

Este documento y la información contenida aquí son propiedad de ITT CCT; las copias son distribuidas en estricta seguridad y no deben ser reproducidas o copiadas, o utilizadas como base de manufactura o ventas de aparatos sin permiso.

The year shall be divided into quarters as follows:

First quarter: January, February, March

Second quarter: April, May, June

Third quarter: July, August, September

Fourth quarter: October, November, December

The cure date shall show the applicable quarter of the year by number, the letter "Q", and the last two digits of the applicable year. Example: May 2022 would be designated by 2Q22.

An elastomeric part cured during any given quarter is not considered one quarter old until the end of the succeeding quarter.

Q11.4 Certification Requirements

When shipping shelf life controlled compounds and storage-life controlled elastomers, Supplier shall include the following additional information on the Certification of Conformance:

- Date of manufacture for shelf-life controlled compounds
- Cure date (QQ/YY) for storage-life controlled elastomers
- Shelf-life expiration date (MMYY) for shelf-life controlled compounds
- Storage life expiration date (QQ/YY) for storage-life controlled elastomers
- Batch and or lot number as applicable
- Date of shipment
- Manufacturer's name

Q11.5 Shelf Life of Uncured Compounds Shipped to ITT Cannon LLC

Items that have exceeded their expiration date shall be removed from the supplier's inventory and conspicuously identified as scrap to preclude inadvertent use. All lots must be segregated and identified to maintain batch and/or lot number and cure date. Shelf life of any uncured material as certified by the material manufacturer will not be extended unless authorized either by the material manufacturer, or by ITT Cannon LLC.

In any case, of conflict between documented expiration dates, the ITT Cannon LLC receiving site reserves the right to return the material to the supplier, or resolve the conflict internally. On the shipment date, uncured items/compounds must have 75% or greater shelf life remaining, but not less than 6 months unless otherwise approved by the procuring site.

Q11.6 Refrigerated, Frozen or Cryogenically-Stored Item

If the Purchase Order specifies Refrigerated, Frozen or Cryogenic, the items shall be shipped under these temperature conditions:

Refrigerated - less than 40° F (4.4° C)

Frozen - less than 10° F (-12.2° C)
Cryogenic - less than -40° F (-40° C)

A temperature indicator shall be included in the shipping container and a Refrigerate / Frozen / Cryogenic sticker as applicable is required on the outside of the shipping container. Packaging shall be appropriate to maintain required temperatures.

Q11.7 Shelf Life of Compounds Applied to Products

Supplier shall maintain a documented system for identification and control of limited shelf life compounds so that compounds that had expired shelf life, were not used on product shipped to ITT Cannon LLC. (Examples of limited shelf life compounds are adhesives and paints).

Q-12 Nonconformance Control and Reporting

Per this requirement, the customer grants no authority to disposition product or process nonconformance's to the organization or its sub-tier suppliers. Repair is not allowed under this clause. The controls and related responsibilities for dealing with nonconforming product shall be defined in a documented procedure.

The organization's documented procedure shall also define the responsibility for review and authority for the disposition of nonconforming product and the process for approving personnel making these decisions.

When a nonconformance is discovered, a review process shall be initiated with the identification and documentation of the nonconformance. This review shall be the initial step performed by the organization to determine if the nonconformance needs to be reported to the customer (see below), and to determine if the nonconformance is minor and can be re-worked to a condition that completely conforms to the drawing or specification requirements.

This review does not negate the requirement to identify, segregate, document, and report and disposition non-conformances.

Non-conformances shall be reported to the customer as soon as it is detected and determined not to be re-workable and may be salvageable. When notification is required, notification shall be within 3 working days after the non-conformance is discovered. This requirement applies to all procurements.

Any non-conformance discovered by the organization, on products in their control, shall be documented by the approved ITT's method of nonconformance reporting. AS9131 is an acceptable means of reporting. This shall include a detailed description of the non-conformance, location (by drawing reference point, hardware reference point, clock location, etc.) and exact callout of the violation by drawing or specification requirement (including sub-paragraph or illustration number). It shall also list what type of inspection revealed the discrepant condition, and what, if any, subsequent actions taken prior to disclosure. Dimensional violations shall include "should be" and "is" dimensions, and tool(s) calibration traceability numbers.

The organization shall ensure that product, which does not conform to product requirements, is identified and controlled to prevent its unintended use or delivery until dispositioned or scrapped after review.

Any request for ITT Cannon LLC disposition to be addressed in writing to the ITT Cannon LLC Purchasing Department via the "Supplier Information Request" (SIR) form MAF-02 (MATL-DI-201-17-01) per procedure MAP-05 (MATL-DI-201-17)

Q-13 Sub-Tier Flow Down Requirements

See Responsibilities 8.4.

Q-14 Packaging and Package Identification (Product preservation and packaging)

Q14.1 Package and Preservation

Supplier must ensure that all items are packaged and preserved adequately to guarantee that the hardware is delivered to ITT Cannon LLC undamaged and free of corrosion.

Unless otherwise specified, all hardware shall be packaged and preserved in accordance with the drawing, applicable specifications, or purchase order requirements. If there is no drawing or specification requirement, hardware shall be packaged and identified in accordance with Aerospace Industry Standards (ATA Spec 300, ASTM D3951 and MIL-STD-2073-1).

Q14.2 Prohibited Packaging

- Wood containers constructed from OSB wafer board, particle board, very thin plywood or any other manufactured wood product that is fragile and will not tolerate handling, stacking and re-closing throughout the entire transportation system and subsequent supply chain handling and forwarding.
- Used containers unless specifically designed to be reusable and are in adequate shape.
- Parts that have contact preservation (oil), or have residual fluids or operating oils, shall not be packed/wrapped in paper bags, bubble wrap, sheet foam, or Kraft paper.
- Skin packs that have film-to-film attachments under the item, making part removal difficult, or subjecting the item to damage during opening. Multi-compartment skins packs or blister packs unless they can be positively re-closed after opening, and provide continued part protection.
- Any type of container closure, or lack of a closure, which will result in safety issues, damaged parts or unserviceable packaging when opened.
- Any packaging material that may cause Foreign Object Damage (FOD) or part contamination, part obstruction or leave non-preservation residue.

Q14.3 Inappropriate Closures

Staples are prohibited as a means of closure for exterior shipping containers.

Staples are permitted in non-closure portions of box type containers, such as bottom closure, side stitching, etc. The portion of the container meant to be opened must remain staple-free. Staples and other penetrating forms of unit package closure also are prohibited for use on bags (polyethylene or paper), bubble wrap, sheet foam, Kraft paper or other

intermediate or interior containers. These types of unit packages must be heat sealed (if applicable) or sealed by folding, taping, Zip-Lock, or zipper sealing, etc.

Q14.4 Fluid-Soaked Packages

Fluid tight packaging shall be as required by hazardous material / dangerous goods regulations and as follows:

- Bagged and the heat-sealed closed in accordance with MIL-DTL-117. The bags shall be made from MIL-PRF-22191, Type I material also known as “bearing bag” material. This method is required for corrodible parts, which have contact preservative.
- For non-corrodible items, residual fluids may be contained by bagging and sealing in heavy duty (6 mil or thicker) zip lock type polyethylene bag.
- If the item has internal fluids, which may be released during transportation, the first bag shall be surrounded by appropriate absorbent packing and enclosed in a second fluid tight bag or package.

Note: The item must be cushioned & the first bag must be strong enough to avoid puncture during transportation, as contamination from the absorbent material may FOD the item.

Q14.5 Exterior Shipping Container

The exterior shipping container shall be sufficiently strong and functional to ensure product delivery, packaging identification and subsequent distribution and must withstand superimposed stacking loads, both as presented to the carrier and as may be expected during shipment.

Q14.6 Hazardous Materials and Dangerous Goods

The Supplier shall define, mark, label and prepare for hazardous goods, dangerous material and/or dangerous equipment for shipment in accordance with Department of Transportation HM181, CFR Title 49, and “Dangerous Goods”, as classified by IATA, IMDG or ICAO.

Due to regulation requirements and potential liability issues, ITT may report violations of hazardous materials & dangerous goods regulations to the appropriate governmental agencies. Note: Jet fuel is a hazardous substance. If an item is purged with 1010 oil, label the exterior shipping container “Purged with MIL-PRF-6081, Grade 1010 Oil”. If fuel-wetted items have significant cavities that cannot be flushed, even if purged, HAZ MAT shipment may be required.

Q14.7 International Bug Ban on Containers with Solid Wood

Containers, dunnage, pallets & skids other than those containing non-manufactured coniferous lumber shall be used when possible. If containers with solid wood components must be used, they shall be certified and marked bug free in accordance with ISPM 15 and/or as indicated by <http://www.aphis.usda.gov>

Q-15 Package Identification Requirements.

Q15.1 Application

Bar code identification (labeling) is required on all exterior containers. Labels must be located to allow the markings to be easily read when stored on shelves or stacked, and to ensure marking will not be destroyed when the container is opened for inspection. When stencils are used, ink must be black waterproof.

Instead of using labels, it is permissible to print identification information directly on the container or packing slip as long as all other requirements are met.

Q15.2 Bar Coding General

Bar code labels shall be printed directly on or be permanently affixed to the exterior shipping container.

Additional internal packaging requirements may be specified by the Purchase Order, specification and/or drawing.

Bar codes shall be Code 39 symbology, also referred to as 3 of 9, and printed in medium density or code 128 symbology printed in high density.

Bar code height shall be 0.375 inches. The human readable text shall be in English. The characters shall be 0.110 to 0.125 in high, & shall be left justified over the bar code information.

The margin, or quiet zone, is an area surrounding each bar code and shall be a minimum of 0.25 inches at the left and right end of each bar code to decrease bar code reading errors.

Data identifiers shall appear in text on the label within parentheses immediately following the item (such as "Part Number (P)"). Data identifiers shall be programmed to precede the item in the bar code (part number text "3001488-113" coded as "P3001488- 113"). No space, or other character, shall be allowed between the data identifier and the part number.

Label material/paper shall be white with black printing for maximum contrast. The label may be self-adhesive, either pressure-sensitive or dry gummed, or held in place on the package with a self-adhesive over-laminate.

Critical spacing dimensions for all fields on exterior container label (figure 1).



Note: in Part Number field above, the bar code contains the characters "P3073609-1" with start & stop characters at each end.

Figure 1 (Critical Label Spacing)

Readability:

- Bar Codes shall conform to AIM BC1.
- Check digits and confirmation characters (\$, /, + %) shall not be used.
- X dimension (width of narrow segment) shall be from .010 to .015 inches. Ratio of average width of wide sections to average width of narrow sections shall be from 2.8:1 to 3.2:1. The inter-character gap should be the same as the X dimension.
- Reflectivity and contrast shall be measured at 660 nanometers. Bar codes shall meet one of the following contrast requirements:
 - Print contrast signal $\geq 75\%$, or
 - Minimum reflectance difference $\geq 37.5\%$

Distinguish numeric zeros from the letter "O" by using "Ø", "□" or similar character for human readable data.

Q15.3 Exterior Container Labels

A representative sample of an acceptable label is shown in Figure 2.

- Minimum label size shall be 3.937 inches (100 mm) high by 6.0 inches (152 mm) wide.
- Maximum label size shall be 5.0 inches (127 mm) high by 6.5 inches (165 mm) wide.

From: Supplier Name 1234 E. Drive Rd. City, State, Zip...	To: ITT Cannon Corp 1234 E. Drive Rd City, State, Zip...
P.O. Number(K): G00002164 [Barcode]	
Item Number(4K): 0052 [Barcode]	
Part Number(P): 2-063-320-31 [Barcode]	
Quantity(Q): 1234567 [Barcode]	Shipment Number: 12345678 [Barcode]
Optional(Z): H12345678901 [Barcode]	Box ___ of ___
COUNTRY OF ORIGIN: _____	

Figure 2: Sample Exterior Container (Label not to scale)
"To" address to be as indicated on the purchase order.

Notes:

- Some purchase orders show a combination of purchase order number and line item number (example:G00002164-0052). In this example, the 0052 is not part of the purchase order number, but is the line item number, which shall go on the second line of the label (Figure 2).
- Hand annotation of Box _ of _ numbers is acceptable and is required on boxes only. This field required for all boxes including Box 1 of 1.
- The optional block is for additional supplier information, which may be human-read by ITT Cannon LLC, but will not be read by bar code scanners.
- Data Identifiers, including prefix, shall be separated from item by a colon.

Q15.4 Detailed Field Requirements

- Data Area is space containing field title, human-readable data, and bar coded data.
- Data Area dimensions are shown in (Height, Width) inches; these are minimum values.
- Valid data identifiers are shown in parenthesis prefixing bar code item. The data identifier must be imbedded in the bar code as a data identifier - not as the data itself. Character lengths shown do not include data identifiers.

Data identifiers Bar code prefix)	Item
-----------------------------------	------

This document and the information contained herein are the property of ITT CCT; copies are issued in strict confidence and shall not be reproduced or copied, or used as the basis of manufacture or sale of apparatus without permission.

Este documento y la información contenida aquí son propiedad de ITT CCT; las copias son distribuidas en estricta seguridad y no deben ser reproducidas o copiadas, o utilizadas como base de manufactura o ventas de aparatos sin permiso.

56 Technology Drive; Irvine CA, 92618

Avenida del Libre Comercio S/N,
Parque Industrial Nuevo Nogales,
Nogales, Sonora C.P. 84093

QAF-04 Rev. N/C

K	Purchase Order
4K	Line Item Number
P	Part Number
Q	Quantity
3S	Packing Slip Number
Z	Optional (anything except s/n or l/n literal)

Addresses	Data Area (.80, 6.00) for both "From:" and "To:" addresses
(K) PO Number	15 alphanumeric characters, left-justified (flush left) & null filled. (.60, 6.00)
(4K) Line Item Number	4 alphanumeric characters, right-justified with leading zeroes (.60, 6.00). For example, print "0023R" and not "23R", and bar code "4K0023R", not "4K23R". Note: Exceptions to the 4-character length requirement: 1) For SAP POs, 5 alphanumeric characters are required, 2) Rework "W" P.O. item number may be followed by an 'R' making item number 5 alphanumeric characters in length
(P) P/N	25 alphanumeric characters, left-justified null filled. (.60, 6.00)
(Q) Quantity	7 numeric characters, left-justified null filled. (.60, 2.70)
(3S) Shipment Number	8 alphanumeric characters, left-justified null filled (.60, 3.30). If truncation of shipment number is required, only the last 5 right hand numbers shall be used
(Z) Optional	12 alphanumeric characters, left-justified null filled (.80, 2.70)
Boxes	No bar code. Readable text should be .20 to .25 inches high and may be hand-written (.80, 3.30). Legible written characters are acceptable.
Country of Origin	No bar code.

Note: "Null filled" refers to null, meaning "nothing". If a field is null filled, it is filled with nothing.

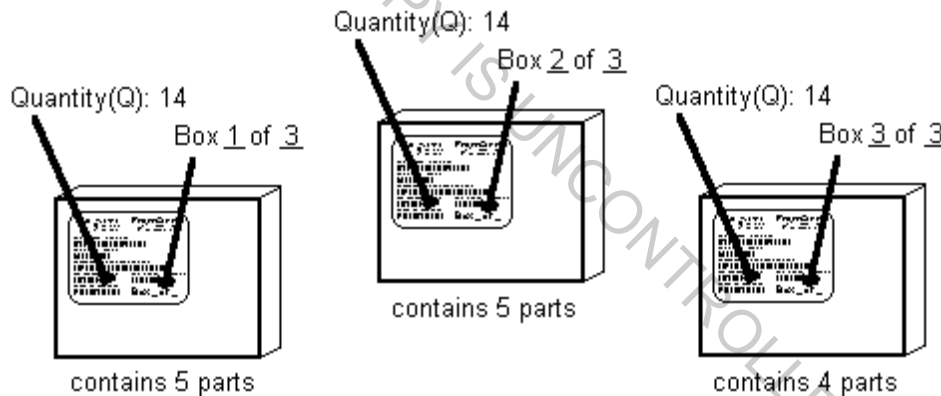

Figure 3: Shipment of 14 Parts with Same P.O. Number, Item, Part Number, Split Across Three Boxes

Note the quantity shown on the Exterior Container for any order shall reflect the quantities that are in the entire order.

Q15.5 Intermediate Package Marking

This document and the information contained herein are the property of ITT CCT; copies are issued in strict confidence and shall not be reproduced or copied, or used as the basis of manufacture or sale of apparatus without permission.

Este documento y la información contenida aquí son propiedad de ITT CCT; las copias son distribuidas en estricta seguridad y no deben ser reproducidas o copiadas, o utilizadas como base de manufactura o ventas de aparatos sin permiso.

56 Technology Drive; Irvine CA, 92618

Avenida del Libre Comercio S/N,
Parque Industrial Nuevo Nogales,
Nogales, Sonora C.P. 84093

QAF-04 Rev. N/C

Intermediate packages, when used, shall be marked with the Part number, as specified on the PO, PO Number, Quantity and Unit of Measure (each, feet, etc.) and Supplier's Name (bar coding is optional). If product is shelf life sensitive, packaging is to be marked by the supplier with the expiration date.

Q15.6 Hand Tags

When the packaging material prohibits the use of containers that allow the application of self-adhesive labels, a tag shall be securely fastened to the material. The Supplier shall ensure that the location and attachment of the tag, under normal conditions, will not cause damage or premature removal of the tag prior to reaching ITT Cannon LLC.

Q15.7 Additional Container Identification

When there are identical part numbers with multiple lot numbers, serial numbers, life tracking numbers and/or multiple orders within the same exterior shipping container, it shall be indicated on the exterior container, such as: multiple lot numbers in this container, multiple serial numbers in this container, multiple life tracking numbers and/or, multiple orders enclosed.

Q15.8 Shipping Documents / Packing Slip

Shipping documents; including the C of C, and/or the packing list, shall be attached to the exterior of container #1 in a weather-proof envelope marked "Packing List Enclosed. Specific additive customer requirements will be specified via PO and linked to receiving inspection line items. The envelope may be placed in a Tyvec ® envelope and securely attached to the exterior of the #1 container to prevent damage.

Identification and traceability (I&T) sheets, if provided, shall be placed inside the container or inside Box 1 of a multiple container shipment, at the top of the container (on top of the item shipped). ATP sheets shall be attached to each item or to the first wrap or bag of each item if direct item attachment is not practical.

Q15.9 Separation of Multiple Part Numbers, Purchase Orders, Item Numbers and Addresses

Shipping containers that contain multiple part number or purchase order items shall be clearly identified on the outside of the container as containing such. Place a label for each internal container on the exterior of the consolidation container. Orders to separate addresses shall be packaged separately and routed accordingly.

Q15.10 Country of Origin and Marking (includes U.S.A.)

This document and the information contained herein are the property of ITT CCT; copies are issued in strict confidence and shall not be reproduced or copied, or used as the basis of manufacture or sale of apparatus without permission.

Este documento y la información contenida aquí son propiedad de ITT CCT; las copias son distribuidas en estricta seguridad y no deben ser reproducidas o copiadas, o utilizadas como base de manufactura o ventas de aparatos sin permiso.

Country of origin marking is mandatory to comply with Customs Regulations or ITT Cannon LLC requirements

Packaging of articles must be legibly, conspicuously and permanently marked with the parts' country of origin. For a product to be called Made in USA, or claimed to be of US origin without qualifications or limits on the claim, the product must be "all or virtually all" made in the U.S. The term "United States," as referred to in the Enforcement Policy Statement includes the 50 states, the District of Columbia, the U.S. territories and possessions. "All or virtually all" means that all significant parts and processing that go into the product must be of U.S. origin. That is, the product should contain no - or negligible – foreign content.

U.S. suppliers should contact the Federal Trade Commission, Division of enforcement, since the phrase "made in U.S.A." is under their jurisdiction. Guidance can be found at the following link, <http://www.business.ftc.gov/documents/bus03-complying-made-usa-standard> . For the purpose of these supplier requirements, the designation "U.S.A." is not adequate country of origin marking.

It is the supplier's responsibility to ensure that marking on the product reflects the true country of origin of the product and that no illegal transshipment through a third country has occurred. The supplier must also ascertain that foreign suppliers are familiar with the country of origin rules.

Q15.11 Electro-Static Discharge (ESD) Labeling and Packaging

Packaging and labeling shall comply with one of the following unless specified in ITT Cannon LLC approved design document:

- 1) ANSI/ESD S20.20 and ANSI/ESD S541 or equivalent, or
- 2) MIL-STD-2073-1, or
- 3) JESD625

Q15.12 Refrigerated, Frozen or Cryogenically-Stored Items

For refrigerated, frozen or cryogenically-stored product, the supplier shall display the type of storage necessary on the outside of the package. Packages must be adequately thermally insulated to ensure temperature requirements are maintained through reasonably anticipated transportation, in-transit delays, transfers and destination.

The supplier's container shall be marked with:

- Net contents
- Manufacturer's production lot number
- Date of manufacture and expiration date
- Date and time shipped
- Warning notes and safety precautions in accordance with federal and state safety and health regulations.

Q15.13 Specific Frozen Packaging Requirements

Supplier shall package material in dry ice to maintain -40 degrees Fahrenheit during shipment, and must use a 24 hour delivery service for this shipment.

Q15.14 Handling, Packaging, and Shipping of Moisture/Reflow Sensitive Surface Mount Devices (Electrical/Electronic Parts)

For protection of moisture sensitive parts, handle, process, and package per the requirements of IPC/JEDEC JSTD-033 unless specified in design document.

Q-16 Electronic and Electrical Components with Lead (Pb) and Pb-free Finishes (Prohibition of materials and chemicals(v))

Prohibition of pure tin:

The uses of Pure Tin Plated finishes are strictly PROHIBITED! Any Tin Plating or Solder processes shall contain no less than three (3) percent Lead composition, unless specifically authorized in writing by the Procuring Agency. These restrictions apply for all types and levels of procurements, with the Supplier responsible for communicating these restrictions to subcontractors or sub-tier suppliers as required.

Exclusion of hazardous materials on EPA 17 and DoD top 10 and RoHS lists:

Every effort should be made to exclude chemicals and compounds found on the EPA 17, DoD top 10, and RoHS (and REACH) lists of hazardous materials (see Attachment 1) in the equipment of supplies furnished under this Purchase Order. In addition, every effort should be made to exclude hazardous materials found on said lists in the processes used to furnish equipment or supplies under this Purchase Order. Reasonable steps shall be taken to ensure that said equipment or supplies are not contaminated with any chemicals and compounds on EPA 17, DoD Top 10, and RoHS lists. Should the Technical Data Package require hazardous materials contained on EPA 17, DoD Top 10, and RoHS lists, notify the ITT Cannon LLC buyer.

Exclusion of mercury:

The equipment or supplies furnished under this Purchase Order shall contain no metallic mercury or mercury compounds and reasonable steps shall be taken to ensure that said equipment or supplies are not contaminated with mercury or mercury compounds. Should the Technical Data Package require mercury or mercury compounds, notify the ITT Cannon LLC buyer.

Elimination of ozone depleting chemicals:

The Clean Air Act (42 U.S. C. Section 7401) Title VI, Section 602A, as amended November 15, 1990, bans the production of Class 1 Ozone Depleting Chemicals (ODC) effective 1 January 1996. Process changes associated with the elimination of these chemicals, as applicable to the manufacture of the item(s) on this purchase order, must be approved by ITT prior to implementation. Notification must include technical rationale validating the new process. Should a reference for ODC be found within the Technical Data Package, please notify the individual whose name appears in the buyer field of the purchase order.

Every effort should be made to exclude Class 2 Ozone Depleting Chemicals in the equipment or supplies furnished under this Purchase Order. In addition, every effort should be made to exclude Class 2 Ozone Depleting Chemicals found on said lists in the processes used to furnished equipment of supplies under this Purchase Order. Reasonable steps shall be taken to ensure that said equipment of supplies is not

contaminated with Class 2 Ozone Depleting Chemicals. Should the Technical Data Package require Class 2 Ozone Depleting Chemicals, please notify the individual whose name appears in the buyer field of the Purchase Order.

Q-17 Material supplied by ITT Cannon LLC

When Supplier performs work on material supplied by ITT Cannon LLC, Supplier is responsible to strictly maintain ITT Cannon LLC lot identity, shall certify that the work was performed on the specific material provided, and is in accordance with the engineering drawing, specification, and/or purchase order requirements. The material certifications and test reports on the supplied material shall be the responsibility of ITT Cannon LLC. All Certifications to the specification requirements called out on the engineering drawings and/or the purchase order shall be submitted with every shipment

Q-18 Preference for Domestic Specialty Metals

Any specialty metals (as defined by the clause) included in any article delivered under this Purchase Order, must comply with the DFARS clauses 252.225-7008, 252.225-7009, & 252.225-7010. The Supplier must flow these DFARS clauses www.acquisition.gov down to all sub-tier suppliers who provide articles made from or containing specialty metals which are delivered under this Purchase Order.

Q-19 First Article Inspection (FAI) Requirements (First Article Inspection)

Supplier is responsible for assuring completion of the First Article Inspection Report (FAIR) per AS9102 for all ITT Cannon LLC design characteristic ITT Cannon LLC generated by Supplier or its sub-tiers.

The FAI requirement applies to each bill of material or parts list item with an ITT CCT part number that is invoked in the product design, including lower level ITT CCT detailed drawings identified on top level assembly drawing(s), and each cavity or tool serial number for products whose dimensions are controlled by the tool. FAIRs may be required on Customer or Supplier Drawings that are non- ITT Cannon LLC designs or CAGE codes if specified on the Purchase Order.

ITT Cannon LLC or Customer FAIR approval does not relieve the supplier of the responsibility and/or liability for full compliance with all contract requirements.

Q-20 Periodic/Repeat FAIs

ITT Cannon LLC reserves the right to exercise the requirement of additional and/or periodic/repeat FAI requirement on a part number basis to assure continued product conformity. Per AS9102 4.6.f, ITT CCT requests a new FAI for each active product after a 2-year lapse in production..

Table 1 – FAIR Event Table*

Event Description	FAIR type due	ITT Cannon LLC FAIR Review Required	Note
New base part number or first time supplied by source	FULL	YES	
New dash number(s) issued and manufactured. See note *	FULL	YES	*Consult SQE to request partial FAIR per AS9102 If ITT approved Full / Baseline FAIR on other dash number(s)
Current FAIR conditionally accepted based on Deviation, Case Record, MRB or Manufacturing Revision authorizing rework or requirement modification	PARTIAL FAIR due on next lot manufactured or expiration of deviation / waiver	YES	
A change in process, material, tooling, or inspection method that can potentially affect form, fit, or function. This includes changes in Approved Sources For Controlled Processes since last approved ITT FAI.	PARTIAL	YES	
Change Special Process source since last ITT approved First Article.	PARTIAL	YES	
A change in manufacturing source or location of manufacturing equipment, including tooling transferred from another Supplier or division of the same supplier	FULL	YES	Consult SQE to request partial FAIR per AS9102
Two year (2) lapse in production *	FULL	YES	Reference Table 1 Notes 1, 2, 3
Two year (2) since last FAIR on continuous production			As required by ITT customer

NOTES (Table 1):*

1. The 1st tier supplier holding the ITT Cannon LLC Purchase Order shall have the responsibility of assuring hardware manufactured internally and/or procured from their suppliers are maintained and are in compliance with the Two Year (2) lapse in production requirement in accordance with AS9102. Evidence of continued manufacturing may be requested by ITT Cannon LLC either at the 1st tier Purchase Order Holders facility or at their sub-tier suppliers as applicable.

2. For Stock / Inventory hardware that was manufactured and placed in inventory/stock at a supplier BEFORE the two year lapse in production (and which was covered by a ITT Cannon LLC -approved FAIR at time of manufacture), a full FAIR with SQE approval will be required for the next lot manufactured.

Documentation and Records

Retention of FAIR Records Exception: FAIR records may not be discarded as long as active shipments of the respective product are being made with ties/accountability back to that specific FAIR record.

ITT Cannon LLC reserves the right to request the FAI package at any time. When requested, the Supplier shall ensure that FAI documentation is provided within 3 working days maximum.

Q-21 Certification of Conformance / Shipping Declaration Document / Packing Slip Requirements (Supplier Identification)

Supplier is responsible for maintaining and supplying accurate and legible certification documentation as objective evidence of meeting drawing, specification, technical data, or purchase order requirements. This includes all special process certificates per Q-23 and reports showing compliance with MIL-SPEC or others.

Q21.1 Certification of Conformance / Shipping Declaration Document / Packing Slip Requirements

A Certificate of Conformance (C of C) shall be provided with each shipment. The C of C can be a separate document, or it can be included as part of the shipping declaration/packing slip text. The following tables list the C of C data/information requirements for each group.

1. Supplier Name and Address
2. Statement that parts conform to the requirements and must clearly state the specification or requirement
3. P.O. and line item number
4. Original Manufacturer' name and part number (when source of supply is a requirement)
5. ITT Cannon LLC part number and as applicable, part revision and/or BOM revision level
6. Quantity shipped (listed quantities to be broken out by lot, and also totaled)
7. Date and identity (hand signature or electronic 'signature') of quality representative or company official
8. Evidence of Source Acceptance or Self Release
9. Maintenance performed
10. Supplier work order
11. Technical data and revision
12. When required by drawing or technical data: Lot numbers Serial numbers Date code 1
15. Date of shipment

Q-22 Government Source Inspection (GSI)

This document and the information contained herein are the property of ITT CCT; copies are issued in strict confidence and shall not be reproduced or copied, or used as the basis of manufacture or sale of apparatus without permission.

Este documento y la información contenida aquí son propiedad de ITT CCT; las copias son distribuidas en estricta seguridad y no deben ser reproducidas o copiadas, o utilizadas como base de manufactura o ventas de aparatos sin permiso.

All work on ITT CCT Connectors' Purchase Orders are subject to inspection and test by the government at any time and any place.

When this clause invoked through the Purchase order, Government inspection is required prior to shipment from Supplier's facility. Government inspections performed will be determined by the delegated government inspection representative and may be conducted during processing, fabrication, or final inspection.

The government's request for source inspection shall specify the period and method for the advance notification and the Government representative to whom it shall be furnished. Request shall not require more than 2 workdays of advance notification if the government representative is resident in the contractors plant, nor more than 7 workdays in other instances

NOTE: Do not proceed with fabrication/manufacture processing until government mandatory inspection points (GMIPs) are added to organization's manufacturing planning. GMIPs shall not be by-passed unless authorized in writing by the government inspection representative. Organization shall request and include the documents specified in the government delegation, in the shipment.

Q-23 Control of special processes

Supplier must be approved by ITT Cannon LLC to perform required special processes or preferable NADCAP certified.

Certification by a responsible representative of the Supplier shall be included with each shipment. Certificate shall indicate all special processes performed, applicable specifications (including class, type, grade, etc.) and the name of the special processor(s).

Special Processes:

- Castings/Forgings
- Plating
- Heat Treating
- Metal Joining
- Surface Finish/Coating/Treatment
- Testing (NDT Chemical Environment, etc.)
- Adhesive Bonding and Plastic Fabrication
- Printed Wiring Board Fabrication
- Destructive testing (i.e. retention / extraction, insertion, crimp, hardness, etc.)

Q-24 Notification of product change

The organization shall not make any changes in product design, composition, configuration (including form, fit, function, or interchangeability), material, fabrication or processing.

In the event the PO contains customer designated 'critical processes', the Supplier will notify ITT Cannon LLC of proposed changes in process definition and, will obtain approval from ITT Cannon LLC prior to implementing the change.

Changes affecting processes, production equipment, tools and programs shall be documented. Procedures shall be available to control their implementation. This requirement for notification and approval extends to any sub-contracted operations performed on the defined 'critical processes', by or for Supplier.

E-mail's or verbal communication does not represent formal ITT Cannon LLC' change notification approval. Supplier Quality Engineering representative shall provide guidance and definition of approval requirements, such a FAI, control run, reliability testing etc.

Q-25 Foundry control of cast parts

Foundry control castings are required when new tooling (patterns or molds) is made, when a change is made in gates, risers, chills, or as-cast shape, or when a pattern is transferred to a different supplier. Foundry control castings shall be submitted to ITT Cannon LLC for review and approval, as required below, prior to initiation to continuation of production. Foundry control castings are in addition to purchase order end item quantity requirements.

- a) Radiographic film of foundry control castings and test report shall be reviewed and approved by the ITT Cannon LLC' Quality Representative at Supplier's radiographic department or agency. Applicable film and test reports will accompany foundry control castings delivered to ITT Cannon LLC.
- b) Supplier will deliver to ITT Cannon LLC a minimum of one foundry control casting, heat-treated and straightened to the casting drawing requirements, for examination and approval by ITT Cannon LLC Such casting(s) shall be representative of the foundry practices and processes to be used for the production castings.
- c) Supplier shall submit a certified statement of the test bar mechanical properties with each foundry control casting. The test bar(s) shall be from the same melt and heat-treat as the foundry control casting.
- d) Supplier shall submit a certified statement of chemical analysis of the material in the foundry control casting showing the percentage of each element contained in the specimen.
- e) Radiographic film of foundry control castings and test report shall accompany such castings when delivered to ITT Cannon LLC for review and approval at ITT Cannon LLC' facility.

Q-26 Control of Non Destructive Testing (NDT)

Items requiring NDT shall be submitted, complete with part drawing or document establishing NDT requirement, to a laboratory acceptable to ITT Cannon LLC. Test results shall be reported in writing to ITT Cannon LLC, identifying the laboratory and the certified technician who performed and/or evaluated the tests, signed by a responsible laboratory representative. An adequate method of identifying and cross-referencing each x-ray film exposure, report, and item must be provided. When parts are serialized, serial numbers must appear on the report and film with the control number.

- a) Minimum radiographic requirements are included in this purchase order on attached sketch.
- b) Radiographic film of each lot and other NDT results, including foundry control NDT, shall be inspected by ITT Cannon LLC at the laboratory performing the work prior to shipment. Supplier shall notify ITT CCT when the film is ready for review.
- c) NDT reports shall be submitted with each shipment to ITT Cannon LLC and shall include x-ray film when radiographic inspection is required.
- d) NDT Facility must be certified to ISO 17025.

Q-27 Tool proofing & Ongoing Status Tracking

Tooling required for production under POs are subject to acceptance by ITT Cannon LLC. Supplier shall notify ITT Cannon LLC when tooling has completed inspection. ITT Cannon LLC acceptance will be contingent upon review of Supplier data regarding inspection of applicable characteristic ITT Cannon LLC of a quantity of dimensional samples produced by the tooling and tool inspection data. The tooling and dimensional samples produced by this tooling shall conform to the tolerance limits of engineering drawings and specifications stated in this purchase order. This inspection may be under the surveillance of the cognizant ITT Cannon LLC Product Assurance Representative at Supplier's facilities or the data and sample parts will be shipped to ITT Cannon LLC for approval as directed by the ITT Cannon LLC Buyer. Dimensional samples shall be identified with the tool number.

For all tooling and equipment (assets) owned by ITT Cannon LLC that are held and used for production at a Supplier site, the responsible Supplier shall monitor and keep updated records of the status and condition of the asset. At least every 5 year or as required, ITT Cannon LLC will request a reporting of the following details about each asset, which will include at minimum:

- A. Tool / Asset Number
- B. Description of tool (i.e. 2 cavity Injection Mold)
- C. Part number(s) produced by tool
- D. Tool condition (good, needs repair)
 - 1. Must include a detailed description of any repairs needed.
- E. Date of last production run

For all tooling and equipment (assets) owned by government or customer that are held and used for production at a Supplier site, the responsible supplier shall monitor and keep updated records of the status and condition of the asset. The inventory shall be performed at the time and interval prescribed by the Government or Customer.

Upon Government or Customer request, the results of this reconciliation shall be submitted in timely manner as requested. This report shall identify the items along with the applicable location, contract number, and Government acquisition cost (if applicable).

Q-28 Special record retention

This product requires lifetime record retention. Supplier shall define the controls needed for the identification, storage, protection, retrieval, retention and disposition of records. Records shall remain legible, readily identifiable and retrievable upon request by ITT Cannon LLC in compliance with AS9100 or ISO 9001

Q-29 Identification

- A Apply part number and revision letter per applicable drawing note.
- B Bag and tag parts.
- C Tag parts.
- D Identify per PO instructions and requirements.
- E Identify parts in accordance with MIL-STD-130 (latest revision as of the date of purchase order issuance).

Q-30 Liquid penetrant examination

Supplier shall certify Liquid Penetrant Examination to ASTM E-1417.

Q-31 Drop shipments

The material ordered hereunder is to be shipped to other than the ITT Cannon LLC' facilities. Copies of the Product Assurance data required by this order shall accompany the shipment; in addition, one copy of such data and a copy of the Shipping Document shall be mailed to ITT Cannon LLC on the same day that shipment is made.

Q-32 Part Marking Requirements *

ITT Cannon LLC prohibits the use of part marking or numbering that is false or misleading as described in 14 Code of Federal Regulation CFR Part 3. General Requirements*

Marking shall be in accordance with the drawing requirements.

If there are no marking requirements on the drawing, marking shall be in accordance with AS478 Method 30, 35, or 37.

If the additional marking requirements below duplicate information already called out on the ITT Cannon LLC drawing, the duplicate information need not be applied.

Unless the ink color is specified on the drawing, use an ink color that will provide contrast against the background of the hardware.

For any part whose surface, size, or configuration in the marking area is not suitable or is insufficient for Additional Marking requirements Contact Buyer stated on the purchase Order. The ITT Cannon LLC Buyer shall contact SQE.

Determination of an area's lack of suitability or sufficiency for marking must be approved by ITT SQE and an authorization statement with alternate method will then be added to the purchase order.

Additional Marking Requirements (as required):

In addition to the requirements listed above, the supplier shall apply a second line of marking directly below the part number consisting of the letters "MFR" followed by the supplier CAGE Code or SAP vendor number unless this information is in the Acceptance Identification Symbol.

Q-33 INSPECTION/REJECTION

- a) ITT Cannon LLC and/or its customer, to the extent practicable at all times and places, including the place of manufacture, may inspect and test material, work in process, and supplies.
- b) ITT Cannon LLC shall have the right to reject any items or lots of items which are defective in material or workmanship or otherwise not in conformity with the requirements of the applicable PO and to require correction or replacement. Rejected items shall be removed, or if permitted or required by ITT Cannon LLC, corrected in place by and at the expense of Supplier promptly after notice, and shall not thereafter be tendered for acceptance unless the former rejection or requirement of correction is disclosed. If Supplier fails to promptly replace, correct, or remove such items or lots of items which are required to be removed, ITT Cannon LLC may:
 - (1) Replace or correct such items and charge to Supplier the cost occasioned by ITT Cannon LLC thereby;
 - (2) Pay for such items at a reduced price, which is equitable under the circumstances; or
 - (3) Cancel the PO for default.
- c) If any inspection or test is made by ITT Cannon LLC and/or its customer on the premises of Supplier or a lower tier subcontractor, Supplier without additional charge shall provide all reasonable facilities and assistance for the safety and convenience of ITT Cannon LLC and/or customer inspectors in the performance of their duties. In the case of rejection, ITT Cannon LLC shall not be liable for any reduction in value of samples used in connection with such inspection or test. All inspections and tests by ITT Cannon LLC and/or its customer shall be performed in such a manner as not to unduly delay the work.

ITT Cannon LLC reserves the right to charge to Supplier any additional cost of inspection and test when items are not ready at the time such inspection and test was requested by Supplier or when re-inspection or retest is necessitated by prior rejection. Unless otherwise provided herein, final inspection and acceptance of rejection of items shall be made as promptly as practicable after delivery to ITT Cannon LLC' facility. ITT Cannon LLC' failure to inspect or accept or reject items in a timely manner shall neither relieve Supplier from full compliance with all requirements of this Order, nor impose responsibility on ITT Cannon LLC therefore.

- d) Supplier shall provide and maintain an inspection system acceptable to ITT CCT covering the items hereunder. Records of all test and inspection work by Supplier shall be kept complete and available to ITT Cannon LLC and/or its customer for three (3) years following completion of this Order, or for six (6) years following completion of an order pursuant to a U.S. Government contract or subcontract.
- e) Inspection and test by ITT Cannon LLC or its customer of any items or lots thereof does not relieve Supplier from any responsibility regarding defects or other failures to meet PO requirements which may be discovered prior to acceptance or during the warranty period.
- f) If, prior to or at the time of final acceptance or within the warranty period, it was known or should be known by ITT Cannon LLC that the items would not or did not conform to the requirements of the PO, final acceptance shall not be construed as a waiver of any rights ITT Cannon LLC may have with respect to the items purchased under the PO, notwithstanding the failure of ITT Cannon LLC to timely inform Supplier of such nonconformance.

Q-34 WARRANTY

- a) Supplier warrants that all the items furnished hereunder shall:
 - (1) conform fully with all requirements of the PO;
 - (2) conform to approved sample or samples, if any;
 - (3) unless detailed designs have been furnished by ITT Cannon LLC, be fit for the use intended by ITT Cannon LLC; and
 - (4) Be free from defects in material, workmanship, design and fabrication.
- b) In the case of latent defects, the ITT Cannon LLC' rights to corrective action by Supplier shall commence upon ITT Cannon LLC' discovery of the latent defect and notification of Supplier thereof.
- c) If any failure appears, ITT Cannon LLC shall have the right to take the following actions:
 - (1) Retain such defective item(s) and an equitable adjustment will be made in the PO price, or
 - (2) Reject such defective item(s) and an equitable adjustment will be made in the PO price, or

- (3) Reject such defective item(s) and require Supplier to promptly remove and repair or replace such defective item(s) at Supplier's sole expense (including shipping costs), with risk of loss and damage for the rejected, corrected or replacement item(s) while in transit shall be borne by Supplier; or
- (4) Correct or replace such defective item(s) with similar item(s) and recover the total cost (including shipping costs) thereof from Supplier.

Item(s) rejected shall be removed promptly by Supplier at its expense and its risk. All costs and expenses and loss of value incurred by ITT Cannon LLC as a result of or in connection to any defect/nonconformance and the repair, replacement or other correction of any items delivered to ITT Cannon LLC may be recovered from Supplier.

- d) Upon discovery of any defect or failure of any items supplied by Supplier, the following conditions shall apply:
 - (1) ITT Cannon LLC shall furnish written notice to Supplier of the item(s) involved and set forth the nature of the defect(s) or failure(s) discovered
 - (2) As required by ITT Cannon LLC' corrective action policies, after receipt by Supplier of such notification, Supplier shall provide in writing to ITT Cannon LLC the following information:
 - (i) Acknowledgment of the notification given by ITT Cannon LLC of the defect or failure,
 - (ii) The corrective action to be taken by Supplier to remedy the defect or failure,
 - (iii) Disposition instructions regarding the defective material or equipment,
 - (iv) The date that the defective items will be repaired, corrected or replaced as applicable and redelivered to the appropriate destination as directed by ITT Cannon LLC, or
 - (v) With the advance approval of ITT Cannon LLC, submit a proposed price reduction to the PO for ITT Cannon LLC' consideration pursuant to Q35(c)(1) above.
- e) Approval by ITT Cannon LLC of Supplier's design or material used shall not relieve Supplier from any obligations under the warranties in this Q35 clause.
- f) The word "item(s)" as used herein includes materials, equipment, services and data required under the PO.
- g) Any items(s) corrected or replaced pursuant to this Q35 clause shall be subject to all provisions of this clause to the same extent as item(s) initially delivered.
- h) The previously mentioned warranties shall survive acceptance and payment and shall run to ITT Cannon LLC, its customers and the users of these item(s) and shall not be deemed to be the exclusive rights of ITT Cannon LLC but shall be in addition to other rights of ITT Cannon LLC under law, equity, and the terms of the PO.

Q-35 Product Conformance

This document and the information contained herein are the property of ITT CCT; copies are issued in strict confidence and shall not be reproduced or copied, or used as the basis of manufacture or sale of apparatus without permission.

Este documento y la información contenida aquí son propiedad de ITT CCT; las copias son distribuidas en estricta seguridad y no deben ser reproducidas o copiadas, o utilizadas como base de manufactura o ventas de aparatos sin permiso.

Acceptance of the PO and receipt of the items under the PO at ITT Cannon LLC' location certify that items processed under the PO meet all imposed requirements. This includes any and all suppliers or materials, components, processes, or services purchased from a secondary (sub-tier) suppliers that are incorporated into or used to produce, inspect, or test products or services under the PO. Supplier shall:

- Provide (flow down) all applicable specification and standards requirements to sub-tier suppliers;
- Be aware of their contributions to product safety;
- Be aware of the importance of ethical behavior;
- Ensure, by performing physical and/or functional inspections that sub-tier suppliers have complied with the requirements of the PO; and
- Upon request, provide objective evidence to ITT Cannon LLC of compliance to this provision.

Q-36 Foreign Object Damage (FOD) Control

Supplier shall ensure that Foreign Objects and subsequent Foreign Object Damage (FOD) is eliminated from all parts prior to shipment. In addition to maintaining compliance with ITT Cannon LLC site's cleanliness specifications, all suppliers must maintain a FOD free environment during machining, manufacturing, assembly, maintenance, inspection, storage, packaging and shipping.

- Potential FOD includes but is not limited to burrs, chips, dirt, corrosion and contamination resulting from the manufacturing, assembly, maintenance, processing, cleaning, storage and subsequent packaging of parts.
- Supplier must ensure all passageways- cast and/or machined are clear of chips, core material, dirt, breakout of cast walls, etc.
- Prior to closing inaccessible or obscured areas and compartments during assembly, Supplier shall ensure the areas are free of FOD.
- Supplier must ensure all parts are clean and FOD free prior to shipment.
- Supplier is required to maintain a FOD prevention program, which includes prevention and elimination of FOD from the manufacturing processes and work area.

Specific attention should be given, where applicable, to items such as:

- Housekeeping and cleanliness
- Food and beverage control
- Tool and small part accountability
- Loose objects
- Material handling and parts protection
- External cleaning following evidence of external contamination

Supplier shall ensure that the responsibility for the FOD prevention program is clearly defined and appropriate personnel have received FOD awareness training.

Supplier is responsible for flow down of these requirements to their sub-tier suppliers to ensure FOD free products.

Supplier's FOD prevention program and controls are subject to periodic audits by ITT Cannon LLC as deemed necessary to ensure program effectiveness and compliance. This includes, but not limited to, Failure Analysis Reports, Containment and Preventive Corrective Action Plans taken to preclude recurrence. These reports shall be made available and submitted upon request though formal notifications to ITT Cannon LLC

For additional information regarding FOD prevention, refer to National Aerospace Standard NAS 412, "Foreign Object Damage / Foreign Object Debris (FOD) Prevention". The NAS 412 document may be used as a baseline FOD prevention resource

Q-37 Supplier Counterfeit Parts Prevention Requirements

This requirement is intended to prevent suspect and confirmed counterfeit Electrical, Electronic and Electromechanical (EEE) and Material commodities from entering ITT Cannon LLC' supply chain and to standardize practices to:

- a) Specify the flow down of these requirements to applicable suppliers/contractors and their sub-tier suppliers/contractors who are performing work on behalf of ITT;
- b) Maximize availability of authenticated EEE and Material;
- c) Procure EEE and Material from authorized sources where available;
- d) Clear risks with ITT when EEE and Material are not available from authorized sources;
- e) Assure authenticity and conformance of procured EEE and Material;
- f) Control EEE and Material identified as suspect or confirmed counterfeit within the ITT supply chain and in the Supplier/Contract Manufacturers' supply chain;
- g) Report suspect counterfeit and confirmed counterfeit EEE and Material, to other potential users and to Government investigative authorities as required by contract or by law;
- h) This Clause is specific to counterfeit prevention and detection, and not fraudulence beyond counterfeiting.

The provisions of this requirement are in addition to Supplier's responsibility to meet all contractual / purchase order requirements. The requirements support both counterfeit prevention SAE Aerospace Standards: AS5553A and AS6174. Q-37 is not intended to stand alone or to supersede or cancel requirements found in other quality management system documents, requirements imposed by contract, or applicable laws and regulations unless an exemption and variance has been granted in writing by the ITT Cannon LLC Director of Supplier Quality.

Applicability

- a) The requirements apply to all commodity and assembly (EEE and Material purchase orders issued to ITT Cannon LLC suppliers as defined in the applicability tables.

ITT Cannon LLC' suppliers shall flow these requirements down to their lowest level sub-tier suppliers on behalf of ITT Periodic audits

- i. May be performed to assess compliance to Counterfeit requirements.

- ii. Will be determined by ITT CCT and ITT CCT sites.
 - iii. Will assess Counterfeit flow down requirements for compliance.
 - iv. Will be conducted by ITT CCT and ITT CCT sites as applicable.
- b) ITT Cannon LLC EEE and Material commodity Furnished Material will have Authorizing Documentation providing traceability to the authorized source, or material verification testing and inspection, or inventory (receipt history) documentation. Supplier may use ITT Cannon LLC EEE and Material commodity Furnished Material with Authorizing Documentation (ITT CCT C of C)
- v. Supplier will indemnify, defend, and hold ITT Cannon LLC and its affiliates harmless from and against any and all loss or expense incurred by ITT Cannon LLC as a result of the delivery by Supplier to or on behalf of ITT Cannon LLC of suspect, fraudulent, or counterfeit EEE and Material Parts or Assemblies, with the exception of parts included in assemblies acquired in accordance with paragraph (d) above.
 - vi. This note supports SAE Aerospace Standard AS5553A, "Fraudulent/Counterfeit EEE Parts; Avoidance, Detection, Mitigation, and Disposition", and SAE Aerospace Standard AS6174 "Counterfeit Material; Assuring Acquisition of Authentic and Conforming Material".
 - vii. All goods to be delivered will consist of new and unused materials (i.e. No used, refurbished, reclaimed) unless otherwise specified as "used" and no returned parts unless specified on the ITT Cannon LLC PO or contract.
 - viii. Suppliers that supply product for which ITT Cannon LLC is the design authority (build to print) shall certify in accordance with AS5553A that all sources of part supply have been verified as authorized.
 - ix. Suppliers Providing Product under the Supplier's Design Control.

For Suppliers that supply product to ITT Cannon LLC under their own design authority, However, Suppliers should utilize their own counterfeit parts control plan in accordance with applicable regulations to verify parts acquisition from Authorized Sources and to mitigate any related risk of counterfeiting. Industry specifications such as SAE AS5553 – "Counterfeit Electrical, Electronic, and Electromechanical (EEE) Parts; Avoidance, Detection, Mitigation, and Disposition" and AS6174 – "Counterfeit Material; Assuring Acquisition of Authentic and Conforming Material" provide the framework to create a counterfeit parts control plan. Additional information and industry specifications on counterfeit avoidance and detection are available through the SAE Website: <https://www.sae.org>

Suppliers shall maintain objective evidence that sources of supply for material being incorporated into assemblies is from Authorized Sources, and shall make that objective evidence available upon ITT Cannon LLC and U.S. DoD Contracting Officer (when applicable) request for review and audit.

Q-38 Risk Assessment & Business Continuity

As required ITT will request business continuity plan from selected suppliers in support of customer requirements

Items may include but not limited to risk assessments and plans for examples mentioned as follow:

- Natural disasters
- Geo-political hazards
- Supply chain disruptions
- Facility or system issues
- Information loss
- Personnel concerns
- Equipment problems

The supplier will communicate any critical risk scenario that may result in a major disruption.

Q-39 Drawing Key and Critical Characteristics

Any Critical or KEY characteristic noted within an ITT drawing is important to the function of the component. The Supplier must validate all such denoted items in order to ensure capability and reproducibility.

Key Characteristic (KC or KEY): As defined under AS9103, the feature of a material or part whose variation has a significant influence on product fit, performance, service life or manufacturability characteristic for a part, sub-assembly or system: selected geometrical, material properties, functional and cosmetic features which are measurable and whose variation is necessary in meeting Customer requirements.

Critical Characteristics are dimensions that must meet the print requirement to avoid compromising the product's function.

11.0 RECORDS

All records associated with this Procedure will be maintained in accordance with the record retention policy and procedures outlined in QAP-091, or the specific contract requirements, if more stringent.

Form / Reference	Record Holder	Record Location
Supplier Requirements related files.	Purchasing /Supplier Quality	ITT CCT Share intranet System

12.0 SUPPORTIVE DOCUMENTATION

N/A

13.0 REVISION RECORD

Rev.	Date	Change Description/	Originator
------	------	---------------------	------------

This document and the information contained herein are the property of ITT CCT; copies are issued in strict confidence and shall not be reproduced or copied, or used as the basis of manufacture or sale of apparatus without permission.

Este documento y la información contenida aquí son propiedad de ITT CCT; las copias son distribuidas en estricta seguridad y no deben ser reproducidas o copiadas, o utilizadas como base de manufactura o ventas de aparatos sin permiso.

56 Technology Drive; Irvine CA, 92618

Avenida del Libre Comercio S/N,
Parque Industrial Nuevo Nogales,
Nogales, Sonora C.P. 84093

QAF-04 Rev. N/C

N/C-H	Details for previous changes available on Revisions N/C to H		
I	08/21/19	<ul style="list-style-type: none"> -Formatted to new procedure template -Added Clause , Q-38 Risk Assessment & Contingency Planning -Formatted "ITT ICS" to "ITT Cannon LLC", -7.0 Definition Section , 22 definitions added 	C.Benitez
J	05/14/21	<p>Added Q-39 Drawing Key and Critical characteristics. Replaced ITT CCT Connectors with ITT Cannon LLC. Added nomenclature QAP-011. Updated shelf life in Q11.2 & Q11.5 from 33% to 75%.</p>	W. Jensen
K	22/Jun/2021	<p>Revised Q-4 Supplier's Quality Control System to reflect actual practice.</p>	Hudnall
L	08/5/2021	<ul style="list-style-type: none"> • 4.0 Reference Documents called through all context of procedure added • 7.0 Special Process, Tier-1 Supplier and sub Tier-1 Suppliers definition • Q-1 added statement to flow down use of latest revision of Finish Specification when special processes. • Q-9, Q-5 added statement to specify tolerances requirement for Calibration Service providers" • Q-13 Paragraph Removed and referenced to 8.4 • Spelling Check & formatting minor changes • Conversion to QAP-011 new document Number (formerly QDI- 506-12) 	C.Benitez
M	Jun 20, 2022	<ul style="list-style-type: none"> • Approvals: Replaced J. Akzin with S. Williams. • 1.0: Replaced 'ICS' with 'CCT'. • 3.0 Updated ITT callout. • 4.2.5: corrected spelling of 'Property' • 10.2: Removed "notified and". • Q-7: revised certificate details and removed "The following statement shall be included on the certificate". Added reference to Q-21. • Q-11.3: 2022 was 2008. • Q-20: Revised last sentence from "ITT CCT requests a new FAI every 2 years for each active product." Added to table 1: "As required by ITT customer" • Q-21 Added statement "This includes all special process certificates per Q-23 and reports showing compliance with MIL-SPEC or others." 	Hudnall

This document and the information contained herein are the property of ITT CCT; copies are issued in strict confidence and shall not be reproduced or copied, or used as the basis of manufacture or sale of apparatus without permission.

Este documento y la información contenida aquí son propiedad de ITT CCT; las copias son distribuidas en estricta seguridad y no deben ser reproducidas o copiadas, o utilizadas como base de manufactura o ventas de aparatos sin permiso.

		<ul style="list-style-type: none"> • Q-23: Added statement regarding destructive testing. • Q-27: Added requirements regarding asset status reporting. • Q-30: Corrected spelling of 'Penetrant'. 	
N	Jan 22, 2024	<p>Update Quality Clause No. 27 to show: <i>At least every 5 year or as required, ITT Cannon LLC will request a reporting of the following details about each asset</i></p> <p>Approvals: Remove Scott Hudnall</p>	Purchasing and Supplier Quality

THIS HARD COPY IS UNCONTROLLED